

Molteni & C

JEANNE — CHRISTOPHE DELCOURT 2026

1—
3



An expression of architectural precision, the Jeanne coffee table features a fulcrum base around which two overlapping tops are set, highlighted by a thin metal sheet that introduces a visual pause, creating rhythm and a delicate play of shadows. Each element simultaneously supports and envelops the other within an interlocking system. The two tops embrace the base, which joins and supports them, making them appear suspended above the lower plane in a refined balance between solidity and lightness. This ingenious construction also takes on the role of a connecting element for the Edmond sofa system, expanding its functional possibilities.

DATASHEET

REGISTERED
DESIGN

2026

FINISHES

GLOSSY LACQUERED
LOWER AND UPPER TOP
FINISHES

copper
dolomite grey
platinum
burgundy
anthracite
pine green

FINISHES
SOLID WOOD INSERTS

coffee oak
amber oak
sunrise oak

MARBLES FINISHES
UPPER TOP

Marbles (Cat. M1)
black marquina

Marbles (Cat. M5)
red lepanto
calacatta
rain forest green

Marble (Cat. M7)
breccia capraia

Quartzite
avocadus green

TECHNICAL INFORMATION

SOLID WOOD INSERTS

Solid ash wood (Fraxinus Excelsior) stained.

STONE TOP

Stone with stain resistant and water-repellent treatment.

GLOSSY TOP

Medium density fibreboard lacquered in glossy colours from the range.

UNDERTOP FRAME

Painted aluminium.

FEET

Painted aluminium with plastic non-slip tips.

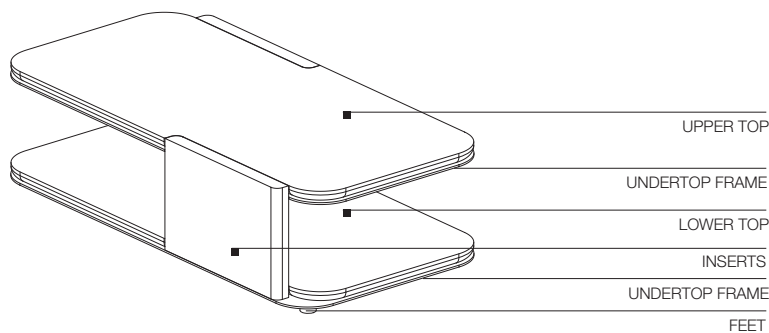

DATASHEET

REGISTERED
DESIGN

2026

DIMENSIONS

Notes

The lower top can only be made in glossy lacquer.

small tables

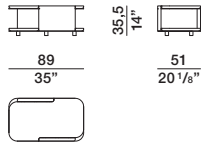

JTR1

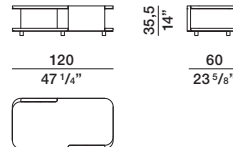

JTR2

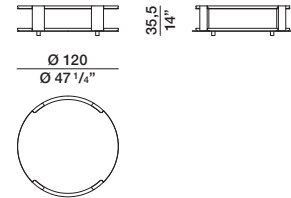

JTT1

Molteni & C

3—
3

small tables

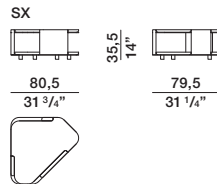

JTS1 dx-sx

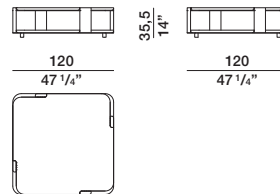

JTQ1

DATASHEET

REGISTERED
DESIGN

2026