

# Molteni & C

## **MONK —** TOBIA SCARPA 1973 / 2025

1—  
2



For 2025, Molteni&C proposes a re-edition of the iconic Monk chair, originally designed by Afra and Tobia Scarpa in 1973. Preserving the character of the original, Monk presents a solid wood frame made of two trestles attached to metal tubing creating a single element for the seat and back. The structural parts are joint by screws with the decorative touch of large hubs in burnished steel. The seat structure is made of two hide leather sections shaped for comfort and available in any color from the Molteni&C collection. Monk is also proposed in a lower and wider armchair version, designed to enhance any living space.

### DATASHEET

REGISTERED  
DESIGN

2026

## FINISHES

### BASE FINISHES

coffee oak  
black oak  
American walnut

### COVERS

hide leather in Molteni range colours  
(Product with NON removable cover.  
Any replacement of the covering must be carried out in-house by the company)

# Molteni & C

## TECHNICAL INFORMATION

### BASE

Solid Ash and American walnut wood.

### STRUCTURE

Painted steel frame.

### FEET

Plastic material.

### OUTER COVER

Hide leather in Molteni range colours.

2—  
2

### CHAIR

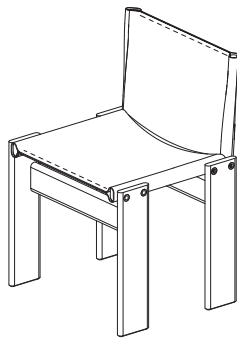

### ARMCHAIR

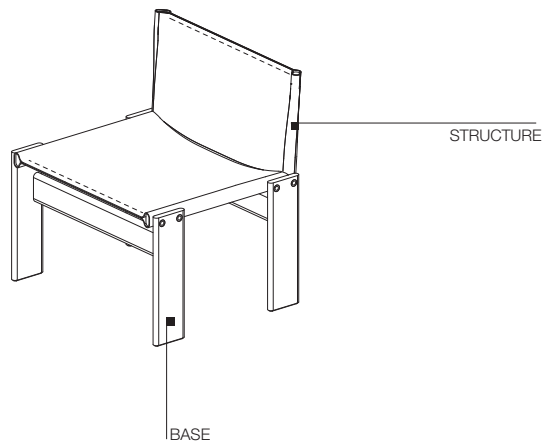

## DIMENSIONS

### chair

#### MSD1

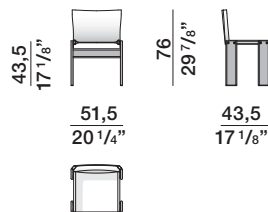

### armchair

#### MPL1

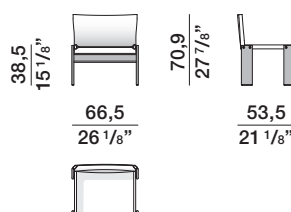

## DATASHEET

REGISTERED  
DESIGN

2026