

# Molteni & C

## EMILE — CHRISTOPHE DELCOURT 2025

1—  
5



Progettato per rispondere alle più variegate esigenze degli spazi living contemporanei, Emile è caratterizzato da segni grafici distintivi, che percorrono i fianchi, il fronte e l'elegante schienale. Offre una serie di moduli abbinabili e connettabili, permettendo la creazione di configurazioni personalizzabili caratterizzate da comodità e morbidezza: sistemi di seduta vis-à-vis, circolari o semicircolari, oppure configurazioni più lineari, tutte caratterizzate da seduta diretta e accomunate dalla sensazione di movimento, data dalle differenti altezze degli schienali e dalle profondità variabili delle sedute. L'uso di grandi cuscini liberi offre la possibilità di adattare il comfort a seconda delle preferenze di ogni ospite.



Il simbolo indica che questo prodotto è dotato di rivestimento sfoderabile. In alcuni casi, il prodotto è sfoderabile, ma solo da personale qualificato; questa evenienza viene evidenziata nelle avvertenze.



Il simbolo indica che il prodotto è disponibile, su richiesta, in versione ignifuga in ottemperanza alle normative BS 5852 e TB 117-2013.

È responsabilità dell'acquirente verificare che il prodotto sia idoneo e conforme ai requisiti richiesti per la destinazione d'uso e alle normative vigenti nel luogo di destinazione e utilizzo del prodotto.

SCHEDA  
TECNICA

REGISTERED  
DESIGN

2025

## INFORMAZIONI TECNICHE

### INTERNO STRUTTURA SEDUTA

Telaio composto da legno massello di Abete (Picea abies) e pannelli di particelle di legno, con cinghie elastiche.

### INTERNO STRUTTURA SCHIENALE

Telaio metallico portante.

### IMBOTTITURA STRUTTURA SEDUTA

Poliuretano espanso ad alta portanza. Fodera in vellutino accoppiato.

### IMBOTTITURA STRUTTURA SCHIENALE

Poliuretano schiumato a freddo in stampo con tamponamenti in poliuretano sagomato e fodera in cotone/ fibra poliestere.

### CUSCINI SCHIENALE

Insero in poliuretano espanso, fibra di poliestere riciclata, fodera in cotone 100%.

### CUSCINI SCHIENALE ORNAMENTALI

Fodera in cotone 100%, fibra di poliestere riciclata.

### PIEDINI

Alluminio verniciato con puntali antiscivolo in materiale plastico.

### RIVESTIMENTO ESTERNO SFODERABILE

(Vedi scheda allegata, specifica del rivestimento).



PRODOTTO DISPONIBILE  
IN VERSIONE CONFORME  
A TB117 O BS5852

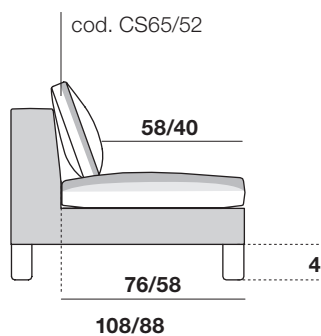

Profondità di seduta solo struttura 76/58 cm

Profondità di seduta con cuscino schienale cod. CS65/52 58/40 cm

Altezza da pavimento a sotto divano 4 cm

## AVVERTENZE

**Per una corretta ergonomia e per godere del massimo confort si consiglia di progettare ogni modulo utilizzando uno o più cuscini schienale, secondo le misure proposte a listino.**

**Oltre alla corretta ergonomia la presenza di questi elementi conferisce al prodotto un aspetto estetico completo ed elegante.**

**DIMENSIONI**

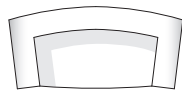
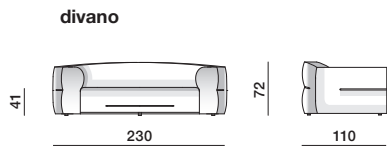

DI2311

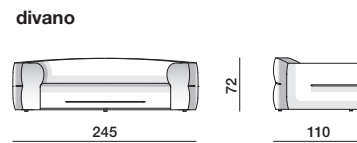

DI2411

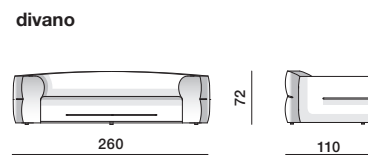

DI2611

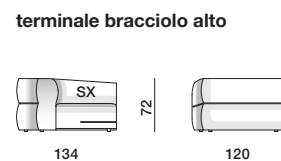

TA1309 dx-sx

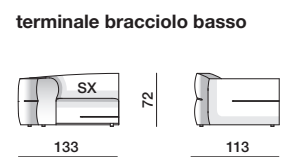

TB1311 dx-sx

**cuscino  
schienale**



CS65/52

**cuscino  
schienale**



CS50/50

**cuscino  
schienale**



CS40/40

**cuscino  
schienale  
ornamentale**

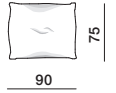

PCU90/75

**cuscino  
schienale**



CS65/52

**cuscino  
schienale**



CS50/50

**cuscino  
schienale**



CS40/40

**cuscino  
schienale  
ornamentale**

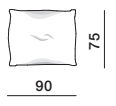

PCU90/75

**cuscino  
schienale**



CS65/52

**cuscino  
schienale**



CS50/50

**cuscino  
schienale**



CS40/40

**cuscino  
schienale  
ornamentale**

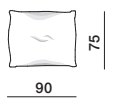

PCU90/75

**cuscino  
schienale**



CS65/52

**cuscino  
schienale**



CS50/50

**cuscino  
schienale**



CS40/40

**cuscino  
schienale  
ornamentale**

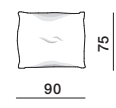

PCU90/75

**cuscino  
schienale**



CS65/52

**cuscino  
schienale**



CS50/50

**cuscino  
schienale**



CS40/40

**cuscino  
schienale  
ornamentale**

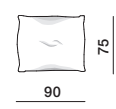

PCU90/75

**DIMENSIONI**

**centrale grande**

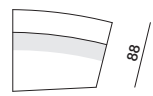
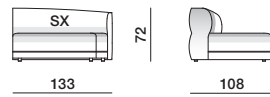

**CN1311 dx-sx**

**centrale piccolo**

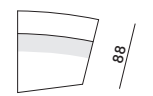
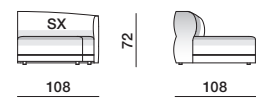

**CN1011 dx-sx**

**angolare**

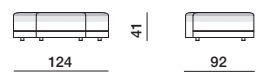

**AN1209**

**angolare con schienale**

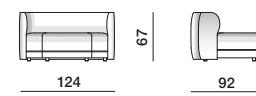

**AS1209**

**angolare grande con schienale**

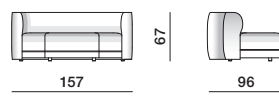

**AS1509**

**cuscin  
schienale**



**CS65/52**

**cuscin  
schienale**



**CS65/52**

**cuscin  
schienale**



**CS50/50**

**cuscin  
schienale**



**CS50/50**

**cuscin  
schienale**



**CS40/40**

**cuscin  
schienale**



**CS40/40**

**cuscin  
schienale  
ornamentale**

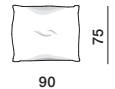

**PCU90/75**

**cuscin  
schienale  
ornamentale**

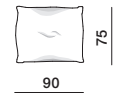

**PCU90/75**

**cuscin  
schienale**



**CS65/52**

**cuscin  
schienale**



**CS50/50**

**cuscin  
schienale**



**CS40/40**

**cuscin  
schienale  
ornamentale**

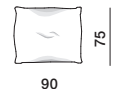

**PCU90/75**

**cuscin  
schienale**



**CS65/52**

**cuscin  
schienale**



**CS50/50**

**cuscin  
schienale**



**CS40/40**

**cuscin  
schienale  
ornamentale**

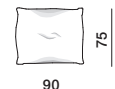

**PCU90/75**

**cuscin  
schienale**



**CS65/52**

**cuscin  
schienale**



**CS50/50**

**cuscin  
schienale**



**CS40/40**

**cuscin  
schienale  
ornamentale**

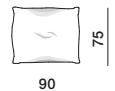

**PCU90/75**

## DIMENSIONI

### isola

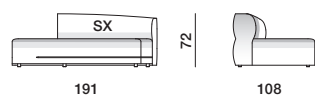

IS1911 dx-sx

### cuscino schienale



CS65/52

### cuscino schienale



CS50/50

### cuscino schienale



CS40/40

### cuscino schienale ornamentale



PCU90/75



Molteni & C

### isola con bracciolo

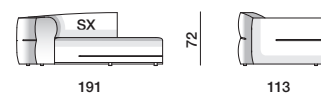

IB1911 dx-sx

### cuscino schienale



CS65/52

### cuscino schienale



CS50/50

### cuscino schienale



CS40/40

### cuscino schienale ornamentale



PCU90/75

### pouf

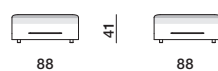

PF0909



PF1109



5—  
5

SCHEDA  
TECNICA

REGISTERED  
DESIGN

2025