

Molteni & C

PANNA COTTA — RON GILAD 2012

1—
2



Panna Cotta low table oval or round. At once delicate and heavy, the paradox lies in the use of materials such as marble and iron to achieve a fragile stability. A small table, it has a slight wave on top reminiscent of the typical Italian soft dessert, from which it takes its name.

DATASHEET

REGISTERED
DESIGN

IX.2023

FINISHES

matt white lacquer with white Carrara marble
matt black lacquer with black marquina marble
matt lacquered green with green alpine marble (only for small round tables)

Molteni & C

TECHNICAL INFORMATION

STRUCTURE

Welded drawn steel painted in the colours of the range. Nylon foot.

TOP

Steel sheet painted in the colours of the range.

COUNTERWEIGHT

Marble in the finishes of the range.

2—
2

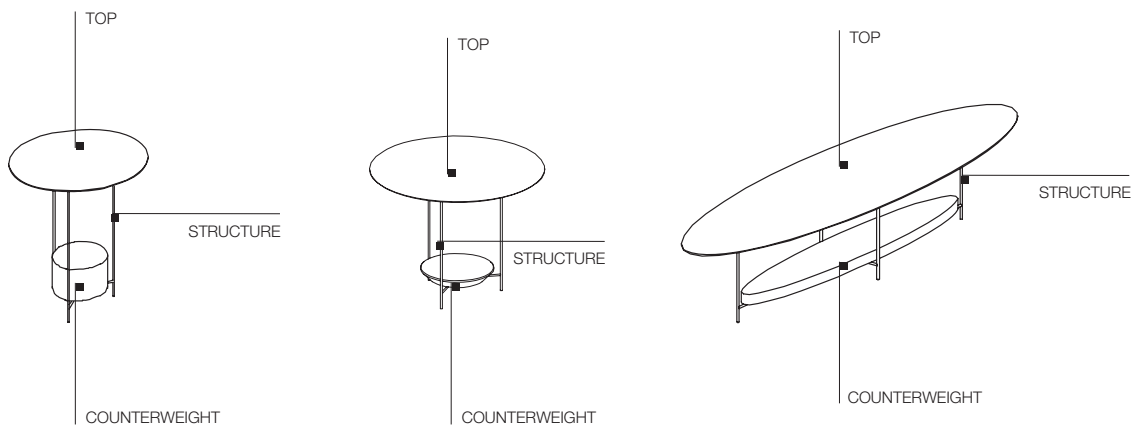

DIMENSIONS

small round table

GPT1

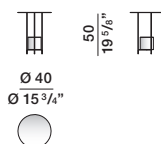

small round table

GPT3

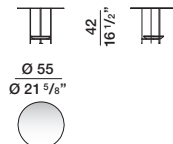

oval small table

GPT2

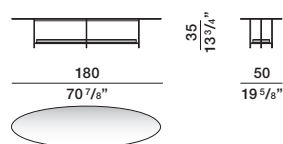

DATASHEET

REGISTERED
DESIGN

IX.2023